

HYPERCLASSIC[®] - Mixer

evolution 6

mixing technology

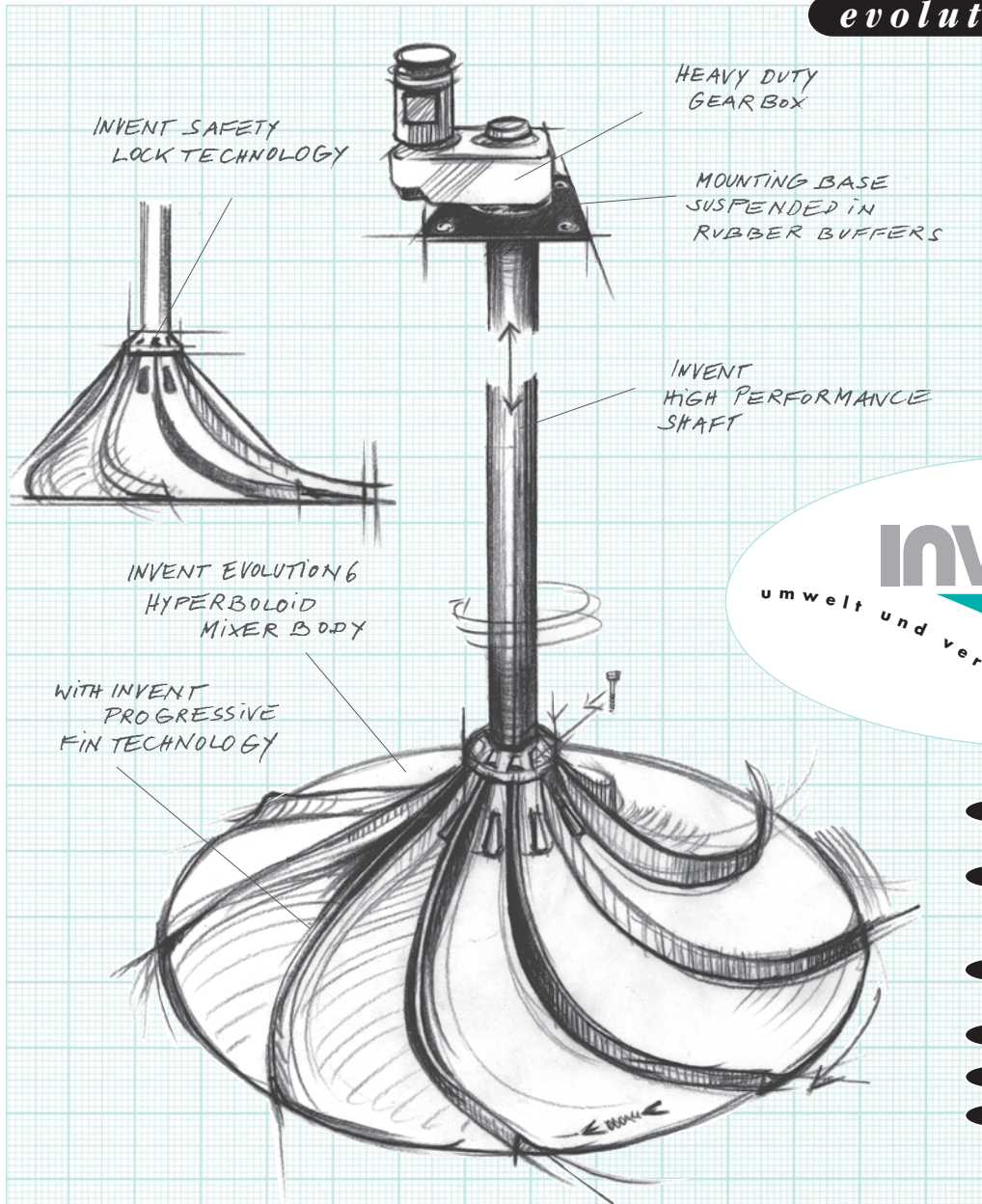

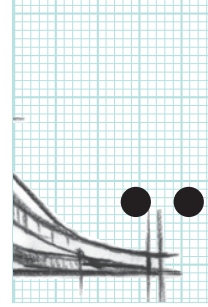
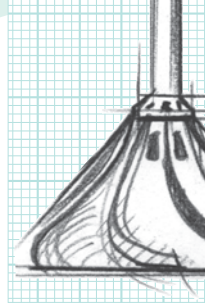

i n n o v a t i o n f o r n a t u r e

The growing pollution of our environment is a problem which concerns all of us. For years water pollution, in particular, has continued to grow in threatening proportions. Water is turning into a more and more limited resource. As a consequence, forward-looking technologies are desperately needed for water and wastewater treatment.

*With great commitment **INVENT** is dedicated to the development and implementation of such technologies, thus creating powerful products which contribute greatly to the preservation of the water quality of our groundwater, rivers and lakes.*

The protection, the preservation and, where necessary, the restoration of our environment will remain one of the most important tasks of our society in the future.

***INVENT** takes on responsibility in this field, with innovative environmental and process engineering.*

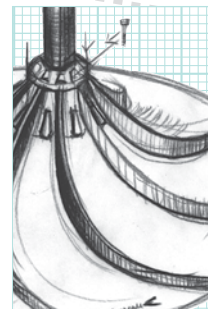
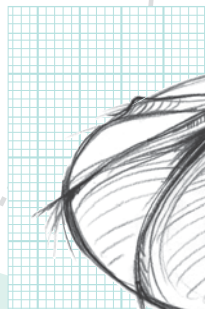

**The Classic –
for over 15 years**

HYPERCLASSIC®

The Classic Mixer

INVENT develops, produces and globally markets innovative machines and plants for the treatment of water and wastewater.

Water and wastewater treatment plants are usually created as a made-to-measure design and lay-out for a particular project.

Depending on the original situation and the intended treatment, various process engineering steps are combined so that the aim of the process engineering is safely within reach. While doing so, the engineer draws from a range of known unit processes. The most important processes from this range are stirring and mixing processes. They play a decisive role in nearly all water and wastewater treatment plants.

Below you will find some examples for important applications of mixing technology in water and wastewater treatment plants.

The table shown to the right is impressive proof of the importance of mixing processes for the water and wastewater treatment.



32 **HYPERCLASSIC®**-Mixers in the anaerobic basins in a large wwtp in Vienna, Austria

Application	Mixing task
● Mixing and equalization tank	Suspension and Homogenization
● Neutralization	Flash-Mixing
● Pre-Mixing of Precipitants	Flash-Mixing
● Precipitation	Suspension and Homogenization
● Coagulation	Suspension and Homogenization
● Biological phosphate elimination	Suspension and Homogenization
● Denitrification	Suspension and Homogenization
● BOD or COD removal	Homogenization and Dispersion
● Disinfection	Flash-Mixing
● Sludge treatment	Suspension and Homogenization
● Storage of chemicals/chemical solution	Suspension

HYPERCLASSIC®

An Overview

INVENT made a significant contribution to the efficiency and cost-effectiveness of such plants by introducing the hyperboloid mixing technology to the market for water and wastewater treatment over 20 years ago. Since then, the hyperboloid mixing technology has been continuously developed and improved. Thousands of successful installations in municipal and industrial water and wastewater treatment plants world-wide impressively demonstrate that the hyperboloid mixing technology has already become the industrial standard in this field of application. With the current version **HYPER-CLASSIC® evolution 6**, the sixth, completely revised and even more efficient version of the classic hyperboloid mixer is now available.

The **INVENT HYPERCLASSIC®**-Mixer is a vertical mixer with a hyperboloid-shaped mixer-body, installed close to the bottom, and a drive mounted in dry position above the water level. Contrary to other products, it was developed and designed especially for applications in the area of water and wastewater treatment.



Optimal design prevents short circuit flows and guarantees optimal reactor behaviour.

The Task

As the above table shows, mixers for applications in water and wastewater treatment are mainly used for suspension and homogenization tasks as well as for intensive mixing and flash-mixing. These tasks should be implemented in a reliable, secure and energy-saving way and with the lowest possible maintenance requirement.

With regard to process engineering the following demands must be met:

- The settling of particles, such as activated sludge flocs, should be reliably avoided (suspension).
- Particles, such as activated sludge flocs, should be distributed evenly throughout the wastewater in order, for example, to efficiently reduce nitrogen and phosphate (homogenization).

- In the anaerobic and anoxic part of the activated sludge tank, turbulences on the water surface should be reduced to a minimum, in order to prevent the transfer of oxygen from the air into the wastewater.
- The energy input should be executed with as little shear force as possible, in order to avoid the destruction of the flocs.
- Short circuit flows should be avoided.
- The reactor behaviour, upon which the process technological lay-out is based, together with the mixer design, should be implemented in a realistic way.

As a consequence of the above mentioned considerations it is important, from a fluid mechanics perspective, to take into account the following points when developing a mixer:

- The mixer-body should be positioned close to the bottom, so that the energy input takes place where the sedimentation of particles should be avoided.
- The mixer should be positioned as centrally as possible in the tank, should run slowly and have a large diameter, so that the

HYPERCLASSIC® -Mixer - efficient and flexible

energy input takes place in a homogeneous way and the particles can be distributed evenly. A design like this is energy-efficient and low in shear force.

- In order to avoid short circuit flows and the correct display of the desired reactor behaviour, it is necessary to manufacture the mixer in various diameters and directions of rotation. These are then chosen according to the tank geometry and the position of the supply and discharge pipes.

Finally, when designing the perfect mixer, all mechanical factors must be considered also:

- The mixer should run smoothly in order to take the strain off the drive and shaft as well as the bridges. This is achieved by a high number of blades. Two-bladed constructions are the most disadvantageous.
- Reaction forces in the vertical direction at the shaft, drive and bridge are to be avoided. They result in a large increase in wear.

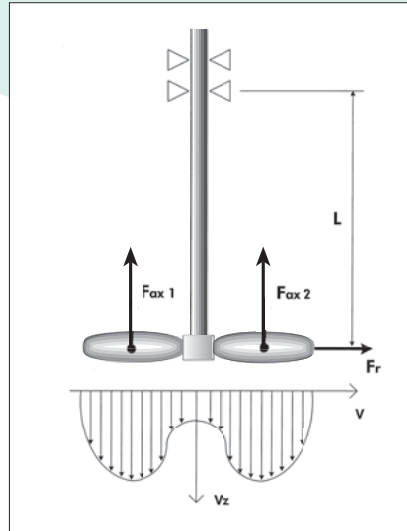

Figure 1: Conventional mixer – high reaction forces on drive and bridge (upwards)

- It must be possible to adjust the mixer to a perfect position on the bridge. The mixer should be galvanically separated from the bridge.
- The drive design should be robust and rather on the large side. It should possess a high service factor and its bearings should have a calculated minimum life expectancy of 100.000 hours. Depending on the installation location, further specific demands must be taken into consideration.

HYPERCLASSIC® An Overview

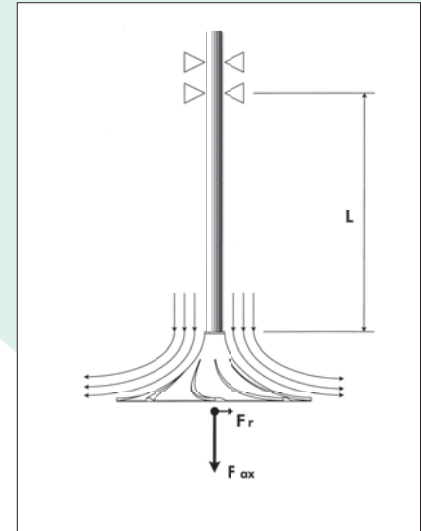

Figure 2: HYPERCLASSIC® -Mixer – small reaction forces on drive and bridge (downwards)

- All parts submerged in water should be non-corrosive and maintenance-free during their life.
- It should be possible to separate the mixer-body of bigger mixer from the shaft for mounting and dismantling purposes.

HYPERCLASSIC®

The Solution

The Solution

The **INVENT HYPERCLASSIC®**-Mixer is a vertical shaft mixer with a hyperboloid-shaped mixer-body installed close to the bottom and a dry-mounted drive. In contrast to other products, it was developed and designed especially for applications in the area of water and wastewater treatment.

The way the hyperboloid mixer functions can be seen in illustration below. The mixer is pictured with its three main components, the drive, the shaft and the hyperboloid mixer-body in a typical tank, which, depending on the type of treatment plant, can be rectangular or round.

Naturally, other shapes of tank are also possible. The hyperboloid mixer rotates close to the bottom and its 8 integrated and specially optimized motion fins thus produce a bottom flow which is directed radially outwards. Particularly at the bottom, this flow is turbulent and thus effectively which whirls up depositions. Along the walls the flow rises upwards and transports all particles until they are just below the water surface. On the water surface the speed has been reduced to such an extent that no further turbulences can be produced and oxygen input via the water surface can be effectively avoided.

Due to the flow on the water surface which is directed towards the shaft, all particles are distributed evenly throughout the tank. Finally, in the centre of the tank the water is again transported downwards along the shaft. A vortex-shaped main flow is thus created throughout the whole tank, which ensures excellent homogenization.

**Optimal design
guarantees high
efficiency**

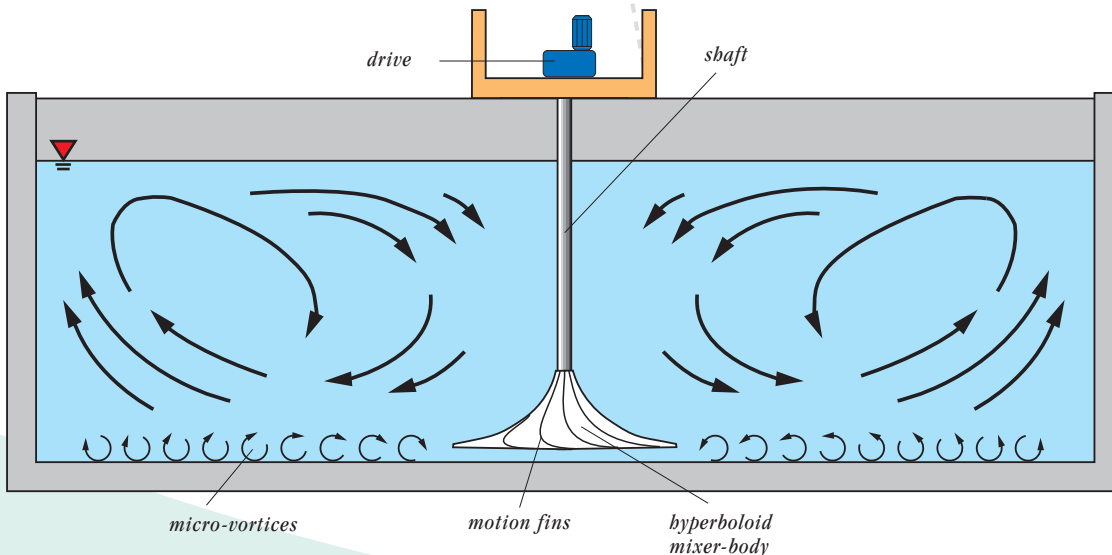

*Schematic
representation of the
hyperboloid mixer with
indication of the
streamlines*

The shape of the hyperboloid mixer is based on complex potential-theoretical calculations. This results in a flow pattern, which, in summary, exhibits the following basic advantages:

- With regard to both quality and quantity, the produced macro-scale flow has the most favourable pattern. By actively re-directing the flow on the surface of the mixer, friction losses are minimized, thus achieving high efficiency.
- The highest velocities and turbulent fluctuating velocities are induced at the bottom. This means that the energy input takes place directly at the bottom, so that the input energy is specifically used to whirl up and suspend sludge flocs and is not wasted anywhere else.
- The flow stays attached to the hyperboloid mixer surface. Flow separations, eddy formations and thus energy losses are prevented. This also boosts the efficiency.
- **HYPERCLASSIC®**-Mixers operate completely without pulsation due to the closed shape and the 8 motion fins (high number of blades).



6 out of 116 **HYPERCLASSIC®**-Mixers in a wwtp in Berlin, Germany

- The uniform, radial flow-off over the complete mixer-body facilitates a flow, which is largely free of periodic fluctuations. The effect of this flow is that the hyperboloid mixer centers itself. Therefore the forces on the gear and the bridges is small. In addition, no oscillations are transferred to the shaft and the bridges which allows a simple and economical bridge construction.
- All reaction forces on the gear and bridges are axial and directed downwards. The radial forces which are generated are very small. Therefore mixers with long shafts can also be constructed without problems.
- The finely graduated diameter range along with the selectable rotational direction, especially in long tanks with lengthwise through-flow, has big advantages with regard to the retention time and the flow in tanks of this type. This contributes to a high operational safety level.

HYPERCLASSIC®

Design and Material Selection

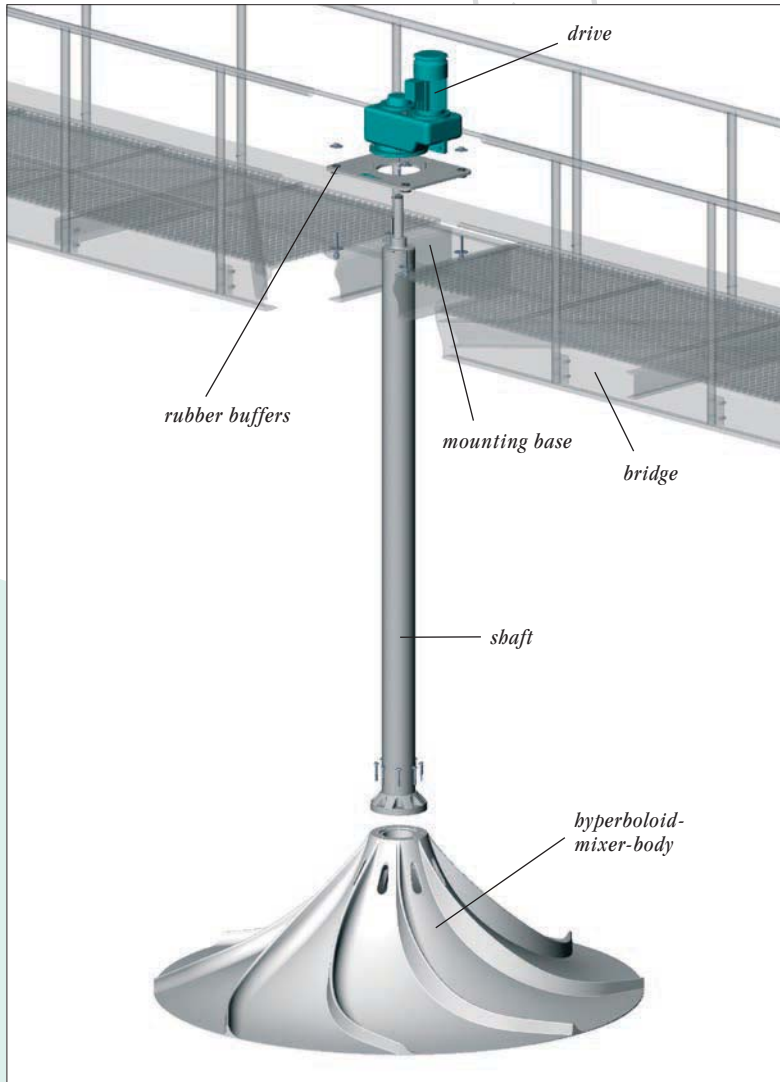

Design and Material Selection

As illustrated in the accompanying blow-up drawing, the hyperboloid mixer is made up of three main components which are precisely fitted to each other, the drive, the shaft and the hyperboloid mixer-body.

Drive

The drive is positioned above the waterlevel and is arranged on a bridge or mounting bracket where it is easily accessible for rarely needed maintenance work.

For wastewater ponds or SBR plants with varying water levels, the hyperboloid mixer can also be mounted on a special float.

Only energy-saving and robust geared motors with reinforced bearings from renowned manufacturers are used. Normally, high service factors are selected and the calculated bearing life expectancy is more than 100.000 h. Special, customer-specific models can be built at any time.

Simple, robust and
safe to operate

HYPERCLASSIC®
Design and Material Selection

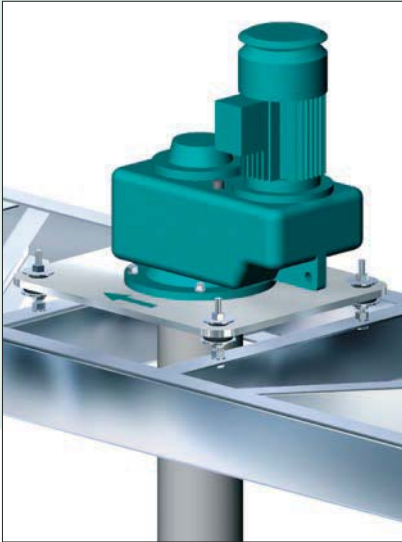

The geared motor sits on a mounting base in a rubber buffer bearing. The propagation of sound waves is thus avoided and the complete mixer is thereby galvanically separated from the bridge.

Shaft

The shaft provides the connection between the drive and the mixer-body. It transfers the required torque, in order to allow the hyperboloid mixer to rotate.

The shaft is manufactured from a specially developed FRP pipe designed for the loads which occur.

It is generously dimensioned and designed for endurance. Through the use of the most modern composite materials, the shaft is very light, extremely corrosion-resistant and flexible. It is particularly easy to mount because of the light weight. All **HYPERCLASSIC®**-Mixers can be designed without a bearing because of their innovative design. The small bearing forces are transferred to the geared motor via the shaft and absorbed there. Consequently, no parts whatsoever which require maintenance lie below the water line.

Hyperboloid Mixer-Body

The hyperboloid mixer-body, developed out of the **INVENT** laboratory in accordance with the most up-to-date knowledge on the mechanics of fluids, is likewise manufactured using fiber-reinforced plastic. The use of the most modern fiber-reinforced composites also guarantees a high-strength, corrosion-resistant and light component here.

The hyperboloid mixer-body is connected to the lower end of the shaft by means of a flange connection. The **INVENT Safety Lock Technology®** is used for this purpose.



This enables a simple and rapid assembly as well as a simple removal even after many years of operation. Under operation conditions the connection is safely protected against self-loosening.

The complete hyperboloid mixer is not just producing a favourable flow field but is also absolutely non-clogging because of the optimal shape and the motion fins which are seamlessly integrated in the mixer-body.

The latest development step "**evolution 6**" uses the newly developed **INVENT Progressive Fin Technology®**. This technology allows for further significant improvement of the efficiency compared to previous versions.

HYPERCLASSIC®

The Installation



1 out of 32 HYPERCLASSIC®-Mixers in a large wwtp in Vienna, Austria



7 out of 33 HYPERCLASSIC®-Mixers in a wwtp in Berlin-Stabnsdorf, Germany

The Installation

Due to the simple construction and the light weight of the components, the assembly can be carried out without big efforts. The hyperboloid mixer is normally delivered to the construction site in a disassembled state. There the shaft is first of all connected to the drive unit by pulling the top end of the shaft into the hollow shaft of the drive. Next both drive and shaft are placed on top of the prepared stainless-steel thread bolts or adhesion anchors on the bridge or the bracket. Then the drive is aligned and is ready for operation after the electrical connection and checking of the oil level.

The last step consists of screwing the hyperboloid mixer-body to the lower shaft flange. Just a short dry run and the **HYPERCLASSIC®**-Mixer is ready for operation.

Of course, the hyperboloid mixer can also be mounted and dismantled in a filled tank. In the theoretically possible case of a motor or drive defect, these components can be exchanged without having to dismantle the complete mixer.

**Simple, problem-free
and quick**

**Low operational costs
due to low energy consumption**

HYPERCLASSIC®

The Operation



45 **HYPERCLASSIC®**-Mixers in a large wwtp in Kuwait City, Kuwait



2 out of 45 **HYPERCLASSIC®**-Mixers in a wwtp in Kuwait City, Kuwait

The Operation

After a short dry run and a check of the direction of rotation the hyperboloid mixer can start operating without any further work. It is designed for permanent operation and does not require any maintenance work, except an occasional inspection of the oil level. Depending on the type of oil, an oil change is carried out once every 1 or 2 years.

Due to the location and the excellent accessibility of the drive this is child's play. There are no work-intensive and unpleasant pulling and cleaning jobs, which for example, is generally the case with submerged drives. Expensive maintenance work, such as the exchange of mechanical seals, are superfluous, because no parts which are subject to wear are installed below water level.



Low maintenance costs

2 out of 48 **HYPERCLASSIC®**-Mixers in a wwtp in Stockholm, Sweden

Lay-out and Design

For the lay-out and design of an optimum mixer it is also essential to consider the reactor design and any further marginal conditions (such as the shape of the tank, type and location of supply and discharge pipes, physical characteristics of the media, desired reactor behaviour, etc.). The mixer and the reactor must form a unit. After an extensive analysis of requirements and definition of the process engineering aims, this will be successful only if there is a range of innovative tools, measuring data and empirical values to fall back on in order to choose and lay out the perfect mixer.

For both the development and the determination of the basis for the layout of its mixers, **INVENT** always makes use of the latest developments in research and the associated technologies. Modern laser-Doppler-anemometry (LDA) and ultrasound-Doppler-anemometry (UDA) processes are therefore used for the determination of speed profiles in the laboratory and in large-scale models. In addition to conventional fluid mechanical methods for scale-up, the most up-to-date numeric simulations (CFD) are applied.

3D-CAD-programs and finite-element-methods (FEM) are used for the mixer design.

The application of mixers, however, also demands process engineering know-how, so that biological reactors can function optimally, short circuit currents can be avoided and the desired reactor behaviour is achieved.

The accompanying diagram shows a numerical simulation of an activated sludge tank with multiple thoroughly mixed stirring reactors, which are created by individual **HYPERCLASSIC®**-Mixers.

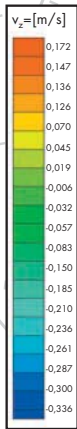

Velocity
in z-direction

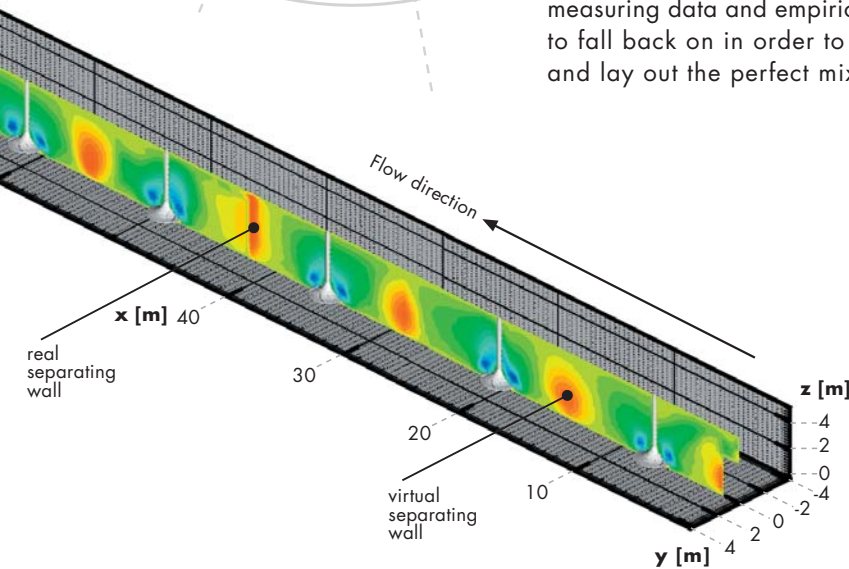

Numerical simulation of an activated
sludge tank



Shop test of an **HYPERCLASSIC®**-Mixer

The Laboratory

Apart from standard applications, time and time again very special terms of reference, tank geometries or mixing tasks must be mastered. In this case, **INVENT** can fall back on the instruments described above, but also on a very well-equipped mixing laboratory as well as on spacious testing facilities which are equipped with state-of-the-art testing and measuring technology.

All conceivable configurations can be replicated to scale and examined. This delivers further fundamental data in addition to the existing foundation for the layout and can of course also be used for the optimization of plants.

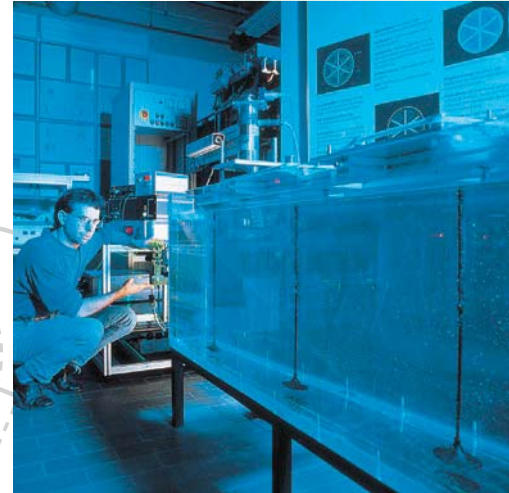

Laser-light-sheet flow visualization in the **INVENT** Laboratories

**Continuous improvement
and quality control**



HYPERCLASSIC® INVENT Products worldwide



INVENT Team meeting

INVENT®, **HYPERCLASSIC®**, **Safety Lock Technology®** and **Progressive Fin Technology®** are registered trademarks of **INVENT Umwelt- and Verfahrenstechnik AG**.

Chosen References

- Berlin Schönerlinde, GER
116 **HYPERCLASSIC®**-Mixers
- Berlin Stahnsdorf, GER
40 **HYPERCLASSIC®**-Mixers
- Berlin Münchehofe, GER
40 **HYPERCLASSIC®**-Mixers
- Stuttgart-Mühlhausen, GER
12 **HYPERCLASSIC®**-Mixers
- Kiel, Germany,
40 **HYPERCLASSIC®**-Mixers
- Stockholm, Sweden,
48 **HYPERCLASSIC®**-Mixers
- Barcelona, Spain,
72 **HYPERCLASSIC®**-Mixers
- Wien, Austria,
32 **HYPERCLASSIC®**-Mixers
- Dornbirn, Austria,
72 **HYPERCLASSIC®**-Mixers
- Zürich, Switzerland,
8 **HYPERCLASSIC®**-Mixers
- Davos, Switzerland,
10 **HYPERCLASSIC®**-Mixers
- Amsterdam, The Netherlands,
16 **HYPERCLASSIC®**-Mixers
- Maastricht, The Netherlands,
32 **HYPERCLASSIC®**-Mixers
- Masan, South-Korea,
104 **HYPERCLASSIC®**-Mixers
- Kuwait City, Kuwait,
45 **HYPERCLASSIC®**-Mixers
- Yokohama, Japan,
12 **HYPERCLASSIC®**-Mixers

Successfull worldwide

The Service

How can we support you with the planning, optimization, modernization of your plant, or just generally with the realization of your ideas? Please ask us about it!

In close co-operation with you, the **INVENT** team will draw up a first draft and will, if necessary, develop it further together with you via numerous iteration steps, until all requirements are met. After the order has been placed an experienced team of engineers will see to it that your project is carried out on schedule. In accordance with the agreement we will deliver and install the plant for you and will also carry out the commissioning. Our service team will reliably take care of all necessary maintenance work.

Professional and innovative

Other Products and Services

Beyond the delivery of components and plants we also offer you general advisory and engineering services in the field of stirring technology. This can be, for example, the layout or optimisation of a stirrer, or the experimental examination of a stirring tank on a laboratory-scale or through numeric simulation.

Furthermore, we carry out large-scale acceptance tests, whereby usually the velocity field, the solid matter concentration distribution and the detention distribution are examined.

INVENT is the market leader for mixers, mixing and aeration systems and membrane aeration systems for the water and wastewater treatment. Please do not hesitate to ask for information about our additional product lines. We would also be happy to offer you complete system solutions for your plants, such as a carefully laid-out and adapted equipment package. We simulate and optimize your plant with the help of appropriate software packages, or else we optimize your plant or building with regard to fluid mechanics.

We are your competent partner for all questions on water and wastewater treatment.

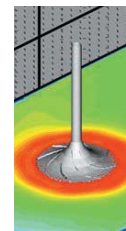

engineering & consulting



software-products



research & development



aeration technology

system solutions

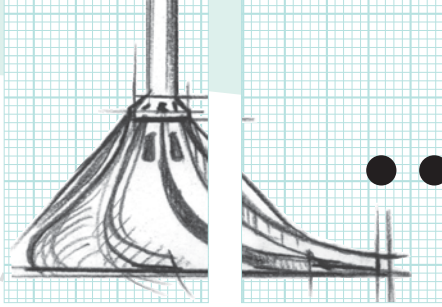
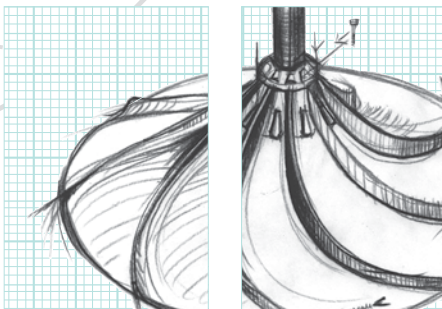



locations

You can reach us at:

INVENT Umwelt- und
Verfahrenstechnik AG

Headquarters:

Am Pestalozziring 21
91058 Erlangen
Germany
Tel: +49 (0) 91 31 690 98-0
Fax: +49 (0) 91 31 690 98-99
E-mail: info@invent-uv.de

US Office:

INVENT Environmental
Technologies, Inc.
218 Little Falls Road
Units 7 & 8
Cedar Grove, NJ 07009
USA
Tel: +1 973 571 2223
Fax: +1 973 571 2474
E-mail: info@invent-et.com

Pacific Office:

INVENT Pacific Pty. Limited
Unit 3, 1 Trappit Place
Orange NSW
Australia 2800
Tel: +61 408 997 774
E-mail: info@invent-pacific.com

Middle East Office:

INVENT Middle East (FZE)
SAIF Office P8-09-07
P.O. Box 121720
Sharjah
United Arab Emirates
Tel: +971 (06) 54 89 139
Fax: +971 (06) 54 89 138
E-mail: info@invent-me.ae

Italy Office:

INVENT Aeration Services S.R.L.
Via Parravicini 30
20052 Monza
Italy
Tel: +39 039 2317125
Fax: +39 039 2302624
E-mail: info@invent-as.it

worldwide

A list of our sales partners
abroad is available by request
or on the internet:

www.invent-uv.de